



Food and Beverage  
Equipment Provider



*French*

**MANUFACTURER  
OF FOOD, COFFEE, BAR  
AND JUICE EQUIPMENT**

---

Fabricant français de matériel  
professionnel pour bars à jus, coffee  
shops, bars et restaurants



**2025**

# SANTOS, 70 YEARS OF HISTORY

SANTOS, 70 ANS D'HISTOIRE

## Who are we?

Qui sommes-nous ? 04

---

## JUICE BAR EQUIPMENT

ÉQUIPEMENTS POUR BAR À JUS 06

### Citrus juicers

Presse-agrumes 08

### Juice extractors and Cold press juicer

Extracteurs de jus par centrifugation  
et pression lente 10

### Our main accessories

Nos accessoires principaux 12

---

## BAR EQUIPMENT

ÉQUIPEMENTS DE BAR 14

### Blenders and Drink dispenser

Blenders et Distributeur de boissons 16

### Ice crushers

Broyeurs à glaçons 18

### Our main accessories

Nos accessoires principaux 20

---

## KITCHEN EQUIPMENT

ÉQUIPEMENTS DE CUISINE 22

### Grater, Dough mixers and Meat mincer

Râpe, Pétrin et Hachoir à viande 24

### Blender

Blender 25

### Our main accessories

Nos accessoires principaux 26

---

## COFFEE SHOP EQUIPMENT

ÉQUIPEMENTS POUR COFFEE SHOPS 28

### Speciality coffee grinders

Moulins à café de spécialité 30

### Espresso coffee grinders

Moulins à café expresso 32

### Coffee shop grinders

Moulins à café boutique 34

### Our main accessories

Nos accessoires principaux 36

---

## Technical data

Données techniques 38

---



GAMME JUS

*Juice range*



GAMME BAR

*Bar range*



GAMME CUISINE

*Food range*

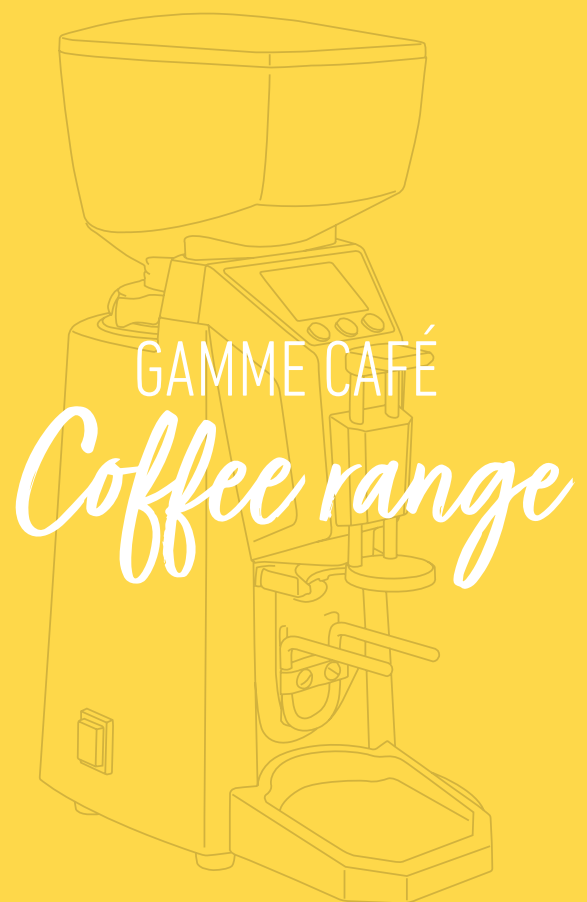

GAMME CAFÉ

*Coffee range*



## 70 YEARS OF HISTORY

Santos, French manufacturer of food, coffee and juice equipment was created in 1954, by André Fouquet.

Originally, the company was providing professional coffee grinders and cheese graters to small retailers. 70 years after the launch of its first products, Santos continues to grow and the R&D department develops new and innovative products based on our savoir-faire with respect to production of motors. This is one of the reasons why Santos products are reputed for their robustness and reliability.

## 70 ANS D'HISTOIRE

Santos, fabricant français de matériel électrique pour la préparation culinaire, le café et les boissons fraîches, a été créé en 1954, par André Fouquet.

À l'origine, l'entreprise produisait des moulins à café et des râpes à fromage professionnels pour les épicerie de quartier. 70 ans après le lancement de ses premiers produits, Santos poursuit son développement en concevant des produits innovants basés sur son savoir-faire en matière de production et de bobinage des moteurs. C'est certainement l'une des raisons pour laquelle la marque Santos est réputée fiable et robuste.



## WORLDWIDE NETWORK AND EXPERIENCE

Santos is now represented in more than 130 countries thanks to its network of resellers and importers who contribute to the success of our brand and products on their markets.

We participate in the most important tradeshows all over the world and develop our products to answer the needs of professionals in Europe, Asia, the Middle East, USA...

## UNE EXPÉRIENCE ET UN RÉSEAU AU NIVEAU MONDIAL

Notre réseau international de revendeurs et d'importateurs représente avec succès la marque et les produits Santos dans plus de 130 pays.

Nous participons aux principaux salons professionnels dans le monde entier et nous développons nos produits pour répondre aux besoins de nos clients en Europe, en Asie, au Moyen Orient, aux Etats-Unis...



## QUALITY, STANDARDS, SERVICE

The thousands of high quality appliances that are produced in our factory are in accordance with the most stringent international regulations (UL, GS, CE, NSF, KC, etc.)\* and can be adapted to all relevant voltages. Besides developing high quality products, our goal is to provide the best commercial and after-sales services. We know that your satisfaction depends on our efficiency.

## QUALITÉ, NORMES, SERVICE

Les milliers d'appareils qui sont fabriqués dans notre atelier respectent les normes internationales les plus strictes (UL, GS, CE, NSF, KC, etc.)\*\* et peuvent être adaptés à tous les voltages locaux.

Notre objectif est de vous fournir un service de qualité en complément de notre gamme de produits. Nous savons que votre satisfaction dépend de notre efficacité.

\*see exhaustive list on website [www.santos.fr](http://www.santos.fr)

\*\*voir liste exhaustive sur le site internet [www.santos.fr](http://www.santos.fr)

handmade  
IN FRANCE



#### MADE IN FRANCE

Offering high quality products 100% made in France has always been a priority for Santos. Since 1954, all our machines are designed and manufactured in our factory in Lyon, and our network of suppliers is local.

Santos appliances are hand-made by operators that are responsible for the appliance from the beginning of the production to the final control (100% tested after assembly).

Our solid international experience allows us to be very flexible, we always keep a maximum of items in stock, and we are able to meet tight deadlines.

#### FABRICATION FRANÇAISE

Santos a toujours accordé une grande importance à la fabrication 100% française de ses appareils.

Depuis le début de l'aventure, en 1954, les produits Santos sont développés et fabriqués dans notre atelier, à Lyon, et notre réseau de fournisseurs est local.

Tous les produits sont montés par des opérateurs qui sont responsables des appareils du début de leur production jusqu'au contrôle final (100% testés en fin de fabrication).

Notre solide expérience internationale nous permet d'être très flexibles et nous sommes en mesure de garantir des délais courts avec un stock complet et diversifié.

Service  
expertise

#### INNOVATION, DESIGN AND ECO-CONCEPTION

Year after year, we develop innovative appliances that are the result of our market experience since 1954.

We focus more and more on developing eco-friendly products, integrating innovative technologies, to meet the needs of our customers: first company to launch a brushless motor in a blender which offers increased longevity and lower power consumption, food-zone materials without bisphenol A, packaging in moulded cellulose... In an eco-friendly approach, we use recyclable materials, such as stainless steel and aluminum, in order to combine robustness and respect for the environment.

Also, our appliances are built to last thanks to their design and the quality of their materials. We guarantee the availability of all spare parts for more than 10 years after the production of our appliances, so that they are durable and endlessly repairable. Recently, Santos has achieved the Longtime® certification for its products. LONGTIME® is the European label for products designed to last. The certification, deliver by an independent control laboratory (and based on 41 requirements), it provides assurance that products are reliable and repairable.



+ Green  
technology

#### INNOVATION, DESIGN ET ÉCO-CONCEPTION

Années après années, nous développons des appareils innovants qui sont le fruit de notre expérience du marché depuis 1954.

Nous attachons toujours plus d'importance au développement de produits respectueux de l'environnement, intégrant des technologies innovantes, pour répondre aux besoins de nos clients : première entreprise à développer un moteur brushless dans un blender offrant une longévité accrue et une consommation électrique plus faible, matériaux en zone alimentaire sans bisphénol A, emballages en cellulose moulée... Dans une démarche eco-responsable, nous utilisons des matériaux recyclables, tels que l'acier inoxydable et l'aluminium, afin d'allier robustesse et respect de l'environnement.

De plus, par leur conception et la qualité des matériaux utilisés, nos appareils sont conçus pour durer. Nous garantissons la disponibilité de toutes les pièces détachées plus de 10 ans après la fabrication de nos appareils, pour qu'ils soient durables et réparables à l'infini. Récemment, Santos a acquis la certification Longtime pour ses produits. Longtime® est le label européen des produits conçus pour durer. Délivrée par un organisme de contrôle indépendant (et basé sur un référentiel de 41 critères transverses), il garantit la robustesse et la réparabilité des produits certifiés.

# Juice Bar Equipment Équipements pour bar à jus

Santos is the juicing  
equipment specialist since  
1954 and provides a wide  
range of juicers for all needs!

Santos est le spécialiste  
de l'extraction de jus depuis  
1954 et propose une large  
gamme d'équipements pour  
répondre à tous les besoins !



**68**

**Juice extractor *Miracle Edition***  
Extract juice from various  
fruits and vegetables (like  
apples, carrots, pineapples...)

**L'extracteur de jus par  
centrifugation *Miracle Edition***  
Faites du jus de tous types de  
fruits et légumes (ex. pommes,  
carottes, ananas...)

Healthy  
& fresh



**70**

**Citrus juicer Evolution**

Make fresh orange, grapefruit or lemon juice

**Presse-agrumes à levier évolution**

Réalisez des jus d'oranges, de pamplemousses ou de citrons



**65**

**Cold Press Juicer**

Prepare fresh cold pressed juices from fruits, veggies, and leafy greens

**Extracteur de jus à pression lente**

Préparez des jus pressés à froid à base de fruits, légumes et herbes

# A wide range of citrus juicers

UNE LARGE GAMME  
DE PRESSE-AGRUMES

11



Since 1954  
Depuis 1954



30l/h



11  
Green  
Vert



11 G  
Grey  
Gris



11 C  
Chrome  
Chromé



### The genuine citrus juicer

Classic citrus juicer (3 squeezers + cover)  
Painted base 11-11G or chromed base 11C

### L'authentique presse-agrumes professionnel

Presse-agrumes Classic (3 ogives + couvercle)  
Socle peint 11-11G ou socle chromé 11C



71C



30l/h



38  
Green  
Vert



38 G  
Grey  
Gris



38 C  
Chrome  
Chromé

38G



15l/h



71C  
Grey  
Gris



### Mefra citrus juicer (1 squeezer)

Grey base 71C

### Presse-agrumes Mefra (1 ogive)

Socle gris 71C



### Citrus juicer (3 squeezers + cover)

Painted base 38-38G or chromed base 38C

### Presse-agrumes (3 ogives + couvercle)

Socle peint 38-38G ou socle chromé 38C



**70**



50l/h



70  
Grey  
Gris

**Lever juicer Evolution 70 (1 squeezer)**  
Painted (70)

**Presse-agrumes à levier 70 Evolution (1 ogive)**  
Cuve et socle peints (70)



- Easy to clean
- Accepts all kinds of glasses and jugs
- Squeezer adapted to all kinds of citrus

- Facile à nettoyer
- Accepte tous types de verres et pichets
- Ogive adaptée à tous les agrumes

**52 C**



40l/h



52G  
Grey  
Gris



52C  
Chrome  
Chromé

**High output Citrus juicer (3 squeezers)**  
Painted base 52G or chromed base 52C  
Accepts all kinds of glasses and jugs

**Presse-agrumes gros débit (3 ogives)**  
Socle peint 52G ou socle chromé 52C  
Accepte tous types de verres et pichets



**10C**



30l/h



10  
Grey  
Gris



10C  
Chrome  
Chromé

**Automatic citrus juicer with lever (1 squeezer)**  
Painted 10 or chromed 10C

**Presse-agrumes à levier (1 ogive)**  
Cuve et socle peints 10 ou chromés 10C

# We have the juice extractor you need

L'EXTRACTEUR DE JUS  
PAR CENTRIFUGATION  
QU'IL VOUS FAUT



**68**



140l/h



**68 J**  
Juice bar  
version:  
delivered with  
pulp tube  
Version bar  
à jus: livrée  
avec un tube  
d'évacuation



**68**  
Stainless  
steel  
Inox



**New generation  
centrifugal juice extractor Miracle Edition**  
Perfect filtration + wide feeding chute

**Extracteur par centrifugation  
nouvelle génération Miracle Edition**  
Filtration parfaite + large introduction



**Equipped with the Ezy-clean™ system:**  
removable bowl and basket.  
**Équipées du système Ezy-clean™ :**  
panier et cuve amovibles.

**28**



100l/h



**50**  
Black  
Noir



**50C**  
Chrome  
Chromé



100l/h



**28**  
Stainless  
steel  
Inox

**Centrifugal juice extractor**  
Perfect filtration

**Extracteur par centrifugation**  
Filtration parfaite

**50**



**Centrifugal juice extractor**  
Painted 50 or chromed base 50 C  
Perfect filtration + wide feeding chute

**Extracteur par centrifugation**  
Socle peint 50 ou socle chromé 50 C  
Filtration parfaite + large introduction



## COLD PRESSED JUICES!

JUS PRESSÉS À FROID!

Heavy duty counter-top cold press juicer for fruits, veggies and leafy greens.

XL feeding tube.

Extracteur de jus puissant pour fruits, légumes et herbes.

Goulotte d'introduction XL.

65

New  
Nouvelle  
version



60l/h



65  
Stainless  
steel  
Inox



**Cold Press Juicer**  
Speed variation (+ 1 filter)

**Extracteur à pression lente**  
Variation de vitesse (+ 1 filtre)

## DIFFERENT TYPES OF JUICE EXTRACTION

DIFFÉRENTES MÉTHODES D'EXTRACTION

There are different processes to extract juice from fruits and vegetables.

Find the juicer adapted to your needs.

Il existe différents procédés permettant d'extraire le jus de fruits et légumes.

Trouvez l'appareil adapté à vos besoins.

### Squeeze Pressage

70 **Citrus juicer**  
Presse-agrumes



This juicer squeezes oranges, grapefruits, lemons and pomegranates. It is suitable for intensive use thanks to its high output.

Permet de presser les oranges, pamplemousses, citrons et grenades. Il est adapté à un usage intensif grâce à son débit élevé.

### Centrifuge Centrifugation

68 **Juice extractor**  
Extracteur par centrifugation



Using centrifugal force, it extracts juice from various types of fruits and vegetables such as apples, carrots, beetroots... It is adapted to intensive use.

Par l'intermédiaire de la force centrifuge, elle extrait le jus de fruits et légumes variés tels que les pommes, carottes, betteraves... Elle est adaptée à une utilisation intensive.

### Slow press Pression lente

65 **Cold press juicer**  
Extracteur à pression lente



It presses very slowly all kinds of fruits, vegetables, and herbs, to extract maximum juice and to preserve vitamins and nutrients.

Presse très lentement les fruits, légumes et herbes pour en extraire un maximum de jus, tout en préservant les vitamines et les nutriments.

# Juice equipment

## L'équipement jus

Our main accessories  
Nos accessoires principaux

### CITRUS JUICERS PRESSE-AGRUMES



11



**Squeezer for grapefruit**  
Ogive Pamplemousse  
Ref #11103 - #38102



**Squeezer for limes**  
Ogive citron vert  
Ref #11150 - #38150



**Squeezer for orange + lemon**  
Ogive orange + citron  
Ref #11101 - #38101



**Drip tray**  
Repose verre  
Ref #11403



38



**Yellow bowl**  
Cuve jaune  
Ref #11204NJ - 38203NJ



**Black bowl**  
Cuve noire  
Ref #11204NN



**Plastic filter grid**  
Grille plastique  
Ref #11201- #38201



**Ornamental ring**  
Cercle anodisé  
Ref #11202 - #38202



**Drip tray**  
Repose verre  
Ref #38402



52



**Squeezer for grapefruit**  
Ogive Pamplemousse  
Ref #52200



**Squeezer for limes**  
Ogive citron vert  
Ref #52150



**Squeezer for orange + lemon**  
Ogive orange + citron  
Ref #52100



**Stainless steel bowl**  
Cuve inox  
Ref #52301



**Anti splash dome**  
Dome anti projection  
Ref #52303



**Stainless steel pulp grid**  
Grille à pulpe inox  
Ref #52302



10



**Complete squeezer**  
Ogive complète  
Ref #10200



**Drip tray**  
Repose verre  
Ref #10903



70



**Complete squeezer**  
Ogive complète  
Ref #70200



**Drip tray**  
Repose verre  
Ref #70710

**JUICE EXTRACTORS** EXTRACTEUR DE JUS PAR CENTRIFUGATION



**68**



**Basket: holes 0,5mm**  
Panier : trous 0,5mm  
Ref #68200



**Basket: holes 0,8mm**  
Panier : trous 0,8mm  
Ref #68200B



**Autoclean basket**  
Panier autoclean  
Ref #68200C



**Pulp tube**  
Tube à pulpe  
Ref #68960



**Fruit pusher**  
Poussoir à fruits  
Ref #68100



**Kit Chefs & Pâtisserie**  
Kit Chefs et pâtisserie  
Ref #68110



**50**



**Basket: holes 0,5mm**  
Panier : trous 0,5mm  
Ref #50200



**Basket: holes 0,8mm**  
Panier : trous 0,8mm  
Ref #50200B



**Autoclean basket**  
Panier autoclean  
Ref #50200C



**Fruit pusher**  
Poussoir à fruits  
Ref #50101

**COLD PRESS JUICER** EXTRACTEUR DE JUS À PRESSION LENTE



**65**



**Complete wiper**  
Racleur complet  
Ref #65269



**Complete 0,3 filter**  
Filtre complet 0,3  
Ref #65230



**Pulp tube**  
Tube à pulpe  
Ref #65105



**Base tube**  
Tube de socle  
Ref #65108



**Fruit pusher**  
Poussoir à fruits  
Ref #65101



**Disassembling tool**  
Outil de dévissage  
Ref #65981

# Bar equipment Équipements de bar

Find the right equipment for your cocktails! Crush, mix, blend, emulsify your ingredients, for the perfect drink!

Trouvez l'équipement adapté à vos cocktails ! Broyez, mixez, mélangez, émulsionnez vos ingrédients pour des boissons parfaites !



**53**

### **Ice Crusher**

Crush ice cubes for your cocktails and granitas

### **Broyeur à glaçons**

Broyez des glaçons pour vos cocktails et granitas



*Let's have  
a drink!*

**54**

**Drink mixer**

Prepare milkshakes and all types of creamy and frozen cocktails

**Shaker électrique**

Préparez des milkshakes et toutes sortes de cocktails crémeux et glacés

**66**

**Compact Brushless Blender**

Blend your cocktails, smoothies, frozen drinks...

**Blender Brushless compact**

Mixez vos cocktails, smoothies, boissons glacés...

**62**

**Expert Brushless Blender**

Make your frozen cocktails, with ice cubes and frozen fruits

**Blender Brushless Expert**

Mixez vos cocktails glacés, avec des glaçons et fruits congelés

# Everything for the bar

| TOUT POUR LE BAR



62

Brushless  
motor



LONGTIME



62  
Black  
Noir

### Expert Brushless blender

Extremely efficient, silent and easy to use, it is the perfect appliance to make smoothies and iced drinks. It crushes all kinds of ice cubes.

### Blender brushless Expert

Extrêmement performant, silencieux et simple à utiliser, il est l'outil parfait pour réaliser les smoothies et boissons glacées. Il broie tous types de glaçons.

## Brushless motor

MOTEUR  
BRUSHLESS

**Brushless motor: extended life expectancy, excellent energy efficiency, low noise level, no overheating.**

Moteur brushless : très grande durée de vie, excellent rendement énergétique, faible niveau sonore et pas de surchauffe.





Brushless motor



62  
Black  
Noir

**Compact brushless blender**

Equipped with the quiet blending technology and a unique lid detection, this powerful, heavy duty and compact blender can quickly crush any kind of ingredients

**Blender Brushless compact**

Extrêmement silencieux et doté d'une détection de couvercle unique, ce blender puissant et compact peut broyer et mixer toutes sortes d'ingrédients



**CHOOSE YOUR BLENDERS ACCESSORIES**

CHOISISSEZ VOS ACCESSOIRES DE BLENDERS

**Colored jug : perfect to avoid allergens cross contact**  
Bol coloré : parfait pour dissocier les préparations contenant des allergènes

**Jug with foam milk agitator**  
Bol avec agitateur mousse de lait

**Jug rinser**  
Rince bol



62



66



# Bar essential

L'INCONTOURNABLE  
POUR VOTRE BAR

It is adapted to intensive use  
and allows a hands free use  
thanks to its high capacity tank  
1.2kg.

Adapté à une utilisation intensive  
et permet un fonctionnement  
« main libres » grâce à son  
réservoir à glaçons de 1,2 kg.



09



09  
Beige  
Beige

#### Traditional Ice shaver

Delivered with one adjustable disc for snow ice  
and crushed ice.

#### Broyeur à glaçons traditionnel

Livré avec un disque réglable pour neige et  
glace pilée.

53



53  
Grey  
Gris

#### Ice crusher

Two sizes of crushed ice. Perfect for cocktails  
(caipirinhas, mojitos...)

#### Broyeur à glaçons

2 tailles de glace pilée. Parfait pour les cocktails  
(caipirinhas, mojitos, ...)

**54**



**54 NEM**  
with on/off  
switch  
Black  
Noir



**54**  
Black  
Noir



**Drink mixer, electric shaker**  
Speed variation, 2 bowls - 3 tools

**Shaker électrique, drink mixer**  
Variation de vitesse, 2 bols - 3 agitateurs



**33E**  
Green  
Vert



**33GE**  
Grey  
Gris



**33CE**  
Chrome  
Chromé



**Bar blender 33 Evolution (1.25 litre container)**  
Painted base 33E - 33GE or chromed base 33CE

**Mixer de bar 33 Evolution (bol 1,25 litre)**  
Socle peint 33E - 33GE ou socle chromé 33CE

**34-1**



**34-1**  
Stainless  
steel  
Inox

**Cold drink dispenser (1 bowl x 12 l)**  
Available with 2 bowls 34-2 or 3 bowls 34-3  
Accepts fruit pieces, High quality compressor

**Distributeur de boissons réfrigérées (1 bac x 12 l)**  
Disponible avec 2 bacs 34-2 ou 3 bacs 34-3  
Accepte les morceaux de fruits, compresseur  
haute qualité



# Bar equipment L'équipement bar

**Our main accessories**  
Nos accessoires principaux

## BRUSHLESS BLENDERS BLENDEURS BRUSHLESS



**62**



**Complete bowl**  
Bol complet  
Ref #62100



**Complete yellow bowl**  
Bol complet  
jaune  
Ref #62100Y



**Complete red bowl**  
Bol complet  
rouge  
Ref #62100R



**Complete bowl with foam milk agitator**  
Bol complet avec  
agitateur de  
mousse de lait  
Ref #62100M



**66**



**Complete bowl**  
Bol complet  
Ref #66100



**Complete yellow bowl**  
Bol complet  
jaune  
Ref #66100Y



**Complete red bowl**  
Bol complet  
rouge  
Ref #66100R



**Complete bowl with foam milk agitator**  
Bol complet avec  
agitateur de  
mousse de lait  
Ref #66100M

## BRUSHLESS BLENDERS BLENDEURS BRUSHLESS



**Complete blade**  
Ensemble  
couteaux  
Ref #62110 - #66110



**Tightening tool**  
Outil de serrage  
écrou bol blender  
Ref #62980



**Blender jug rinser**  
Rince bol blender  
Ref #62970

## ICE CRUSHER BROyeurs À GLAÇONS

---

09



**Drawer**  
Tiroir  
Ref #09502



**Crushing disc**  
Disque de brise  
glace  
Ref #09201



**Locking key**  
Clé de fermeture  
Ref #09126

53



**Ice bucket**  
Bac à glaçons  
Ref #53850

## DRINK MIXER SHAKER ÉLECTRIQUE

---

54



**Transparent bowl**  
Bol transparent  
Ref #54105



**Stainless steel bowl**  
Bol inox  
Ref #54101



**Spherical agitator**  
Agitateur  
sphérique  
Ref #54201



**Winged agitator**  
Agitateur à  
ailettes  
Ref #54203



**Soft agitator**  
Agitateur  
souple  
Ref #54202

## BLENDER BLENDER

---

33



**Complete bowl**  
Bol complet  
Ref #33100



**Complete blade**  
Ensemble couteaux  
Ref #33107

# Kitchen Equipment Équipements de cuisine

Your partner in food preparation since 1954. We offer a complete range of products for all needs, from the preparation of your appetizer to the creation of desserts.

Santos est votre partenaire en préparation culinaire depuis 1954. Nous offrons une gamme complète de produits qui répond à vos besoins, de la préparation de l'entrée jusqu'à la création du dessert.



**12**

## **Meat mincer**

Prepare ground beef, hamburger steaks, sausages, and pâtés

## **Hachoir à viande**

Préparez vos viandes hachées, saucisses, terrines...

# Inspiration & precision



**18**

## **10 litre dough mixer**

Knead your bread dough, pizza dough, shortcrust pastry...

## **Pétrin mélangeur 10 litres**

Pétrissez vos pâtes à pain, pâte à pizza, pâte brisée...

**37**

## **Kitchen blender**

Make soups, gazpachos, purées, vegetable foams, creams...

## **Blender de cuisine**

Réalisez des soupes, gazpachos, purées, mousses de légumes, crèmes, glaces...

**02**

## **Grater**

Grate all kinds of cheese, dried fruit, peanuts...

## **Râpe**

Râpez toutes sortes de fromages, fruits secs, arachides...

# Unleash your creativity

LAISSEZ LIBRE COURS  
À VOTRE CRÉATIVITÉ

02



02  
Beige  
Beige

**Grater (1 standard disc Ø 3 mm)**

**Râpe (1 disque standard Ø 3 mm)**



12-12R

18



12-12  
Stainless  
Steel  
Inox



12-12R  
Red  
Rouge

**Meat mincer**

Stainless steel body.  
Delivered with 3 plates Ø 70 mm

**Hachoir à viande corps inox**

Livré avec 3 grilles Ø 70 mm



18  
Beige  
Beige

**10 litre dough mixer**

Stainless steel bowl  
The ideal dough mixer to make 4kg of hard  
dough

**Pétrin mélangeur 10 litres**

Cuve inox  
Le pétrin idéal pour réaliser 4 kg de pâte dure



## YOUR PARTNER IN THE KITCHEN

**37 41**

VOTRE PARTENAIRE  
EN CUISINE



37 41  
Grey  
Gris



**Santosafe kitchen blender painted base 37**  
Blender de cuisine Santosafe socle peint 37



## CHOOSE YOUR OPTIONS

CHOISISSEZ  
VOS OPTIONS



**21**



**2P**



**41**



**4P**



**Chef stick**

Mix, liquefy and crush all kinds of hot and cold preparations:

- Powerful motor and new pulse function (18 000 rpm)
- High quality blending
- Exclusive patented Santosafe® locking system for the bowl and the cover

Mixez, émulsionnez et broyez toutes sortes de préparations chaudes ou froides :

- Moteur puissant et fonction pulse (18 000 tr/min)
- Qualité de mixage optimale
- Système de sécurité exclusif Santosafe® verrouillant le bol et le couvercle

# Food equipment L'équipement cuisine

Our main accessories  
Nos accessoires principaux

## GRATER RÂPE



**02**



**Grating disc 2mm**  
Disque 2mm  
Ref #02201AD



**Grating disc 3mm**  
Disque 3mm  
Ref #02201BD



**Grating disc 4mm**  
Disque 4mm  
Ref #02201CD



**Grating disc 6mm**  
Disque 6mm  
Ref #02201DD



**Grating disc 8mm**  
Disque 8mm  
Ref #02201ED



**Parmesan disc**  
Disque parmesan  
Ref #02201FD



**Fondue disc**  
Disque fondue  
Ref #02201GD



**Drawer**  
Tiroir  
Ref #02502



**Locking key**  
Clé de fermeture  
Ref #02126

## MEAT MINCER HACHOIR À VIANDE



**12-12R**



**Plate 3mm**  
Grille 3mm  
Ref #12711



**Plate 4,5mm**  
Grille 4,5mm  
Ref #12712



**Plate 8mm**  
Grille 8mm  
Ref #12713B



**Set of 3 sausage cones**  
Jeu de 3 cornets  
à saucisses  
Ref #12804

+



**Plate 20 mm**  
Grille 20mm  
Ref #12803

## BLENDER BLENDER

---



**37**  
—



**Complete 2L  
Stainless Steel bowl**  
Bol complet 2L inox  
Ref #2I



**Complete 2L  
transparent bowl**  
Bol complet 2L  
transparent  
Ref #2P



**Complete 4L  
Stainless Steel bowl**  
Bol complet 4L inox  
Ref #4I



**Complete 4L  
transparent bowl**  
Bol complet 4L  
transparent  
Ref #4P



**Complete blade**  
Ensemble  
couteaux  
Ref #37180



**Chef Stick**  
Chef Stick  
Ref #37110

## DOUGH MIXER PÉTRIN MÉLANGEUR

---



**18**  
—



**Complete bowl**  
Cuve complète  
Ref #18500



**Dough-hook**  
Fourche  
Ref #18120

# Coffee shop equipment

## Équipements pour coffee shops

Santos has been manufacturing high-quality coffee grinders and grinding discs since 1954, for a perfect coffee.

- Quietest grinders on the market
- Constant dose dispensed
- Heat dissipation
- Anti-static system
- Easy adjustment and maintenance

Santos fabrique des moulins à café et meules de broyage depuis 1954, et offre des équipements de qualité pour un café parfait.

- Moulins les plus silencieux du marché
- Régularité de dose
- Dissipation thermique
- Système antistatique
- Réglages et maintenance faciles



**76**

**Kawa Coffee Grinder**  
Developed for  
brewing methods

**Moulin à café Kawa**

Le moulin dédié aux  
méthodes douces

**67**

**I-Grind coffee grinder**  
Exclusive Brushless  
motor: from slow to  
high speed grinding

**Moulin à café I-Grind**

Moteur Brushless  
unique : permet  
de moulin à haute  
vitesse

# Quality & passion



## 59T

**On-demand coffee grinder**  
Grind your coffee on-demand  
for a high-quality espresso

**Moulin à café « on-demand »**  
Moulez votre café à la demande  
pour un espresso de qualité



## 01 BAR

**Barista Coffee Grinder**  
Prepare your specialty coffee  
with this high precision  
grinder

**Moulin à café Barista**  
Préparez vos cafés de spécialité  
avec une précision extrême



## 63

**Coffee shop grinder**  
Ideal to quickly grind large  
quantities of coffee beans

**Moulin à café coffee shop**  
Parfait pour moudre de  
grandes quantités de grains  
de café, en un temps record

# Speciality Coffee

CAFÉ DE SPÉCIALITÉ

**01 BAR**



**01BAR**  
Black  
Noir

**Coffee Grinder – Championship Edition**  
1954 Barista series

**Moulin à café Edition barista**  
1954 Barista series



**76**

**New**  
Nouveauté



Silence

63dB



**76**  
Black  
Noir

**Kawa Mob Coffee Grinder #76**  
Suitable for all types of filtration

**Moulin à café nomade Kawa #76**  
Adapté à tous types de filtration

30 COFFEE SHOP | COFFEE SHOP



**67**

## CREATE YOUR OWN GRINDING WITH I-GRIND #67

PERSONNALISEZ VOTRE MOULIN I-GRIND #67

Choose Choisissez

1

+

2

+

3



**THE GRINDING ADJUSTMENT**  
LA TAILLE DE MOUTURE



**THE MOTOR SPEED**  
LA VITESSE DU MOTEUR



**THE TIMING**  
LE TEMPS DE DISTRIBUTION



New  
Nouveauté

Brushless motor

Silence

63dB



67  
Black  
Noir

**I-Grind coffee grinder #67**  
Exclusive brushless technology

**Moulin à café I-Grind #67**  
Technologie brushless exclusive

# Brushless motor

MOTEUR  
BRUSHLESS

**Brushless motor: no motor heating, offers a wide range of speed variation, low noise level, extended life expectancy.**

Moteur brushless : ne chauffe pas, offre une large gamme de variation de la vitesse du moteur, faible niveau sonore, très grande durée de vie.



# Espresso coffee

CAFÉ EXPRESSO



**40 AN**



8 kg/h



63 dB



40 AN  
Black  
Noir



40APPMN  
Black  
Noir



**Silent espresso coffee grinder**  
Available with mobile coffee tamper 40APPMN

**Moulin à café bar silencieux**  
Disponible avec presse-poudre mobile 40APPMN

**26**



25 kg/h



63 dB



55 W  
White  
Blanc



55 BF/ BAR  
Black  
Noir

**55 BF**



**Automatic silent espresso coffee grinder**  
Black Front Panel 55 BF

**Moulin à café expresso silencieux "automatique"**  
Façade noire 55 BF



26  
Black  
Noir



**Tabletop precision coffee dispenser**

**Doseur expresso de précision sur socle**



**59 T**



25 kg/h



63 dB



59W/59TW  
White  
Blanc



59/59T  
Black  
Noir

New  
Nouveauté



**On-demand silent espresso coffee Grinder**  
Available without integrated tamper #59 / #59W

**Moulin à café silencieux « on-demand »**  
Disponible sans tasseur intégré #59 / #59W



## CHOOSE YOUR VERSION

## CHOISISSEZ VOTRE VERSION

**Extremely fast and silent, the On-Demand coffee grinder grinds and dispenses the precise dose for 1 or 2 espressos, directly in the portafilter.**

Extrêmement rapide et silencieux, le moulin à café On-Demand moule et distribue directement dans le porte filtre la dose précise de café pour 1 ou 2 espressos.

**59 T**

**59 TW**

**59**

**59 W**



**Models available with tamper**  
Modèles avec tasseur intégré

**Models available without tamper**  
Modèles sans tasseur intégré

# Coffee shop grinders

MOULINS À CAFÉ BOUTIQUES  
ET COFFEE SHOPS

01



**01**  
Brown  
Brun

## Coffee grinder with drawer

Available with bag holder 01PS, in pepper grinder version with drawer 01P or in poppy grinder version 01PV

## Moulin à café tiroir

Disponible avec pince-sac 01PS, en moulin à poivre - tiroir 01P ou en moulin à pavot 01PV



04 N



**04N**  
Black  
Noir

**Coffee grinder with bag holder**

**Moulin à café Pince-sac**





**63**



120 kg/h



63  
Black  
Noir

**Coffee shop grinder:**

- Exceptional output: up to 120 kg/h
- Micrometric grinding adjustment
- Makes turkish coffee (output: 36 kg/h)
- Extremely silent
- Santos Ø 120mm grinding discs

**Moulin coffee shop :**

- Débit exceptionnel : jusqu'à 120 kg/h
- Réglage de mouture micrométrique
- Permet de réaliser du café turc (débit : 36 kg/h)
- Extrêmement silencieux
- Meules Santos Ø 120 mm



**Santos Ø 120 mm grinding discs**

Santos offers the possibility to resharpen your grinding discs to give them a second life.

**Meules Santos Ø 120 mm**

Santos offre la possibilité de faire réaffuter vos meules pour leur donner une seconde vie.



**43 N**



43N  
Black  
Noir

**Silent shop coffee grinder with bag holder**  
Painted Black 43N

**Moulin à café boutique silencieux Pince-sac**  
Noir 43N

# Coffee shop Equipment

## L'équipement coffee shop

**Our main accessories**  
Nos accessoires principaux

**01 BAR**



**04 N**



**1kg complete hopper**  
Bac à grains complet 1kg  
Ref #01100



**1kg complete black hopper**  
Bac à grains complet noir 1kg  
Ref #01100N

**01 BAR only**  
01 BAR uniquement



**150g complete hopper**  
Bac à grains complet 150g  
Ref #01115

**01**



**Drawer**  
Tiroir  
Ref #01502



**1kg Complete hopper**  
Bac à grains complet 1kg  
Ref #01100



**1kg Complete black hopper**  
Bac à grains complet noir 1kg  
Ref #01100N

**40 AN**



**Ground coffee receptacle**  
Récupérateur de café  
Ref #40662B



**2kg complete hopper**  
Bac à grains complet 2KG  
Ref #40100



**2kg complete cristal hopper**  
Bac à grains cristal complet 2KG  
Ref #40100c

**55**



**1kg complete hopper**  
Bac à grains complet 1KG  
Ref #55130



**Ground coffee receptacle**  
Récupérateur de café  
Ref #55662

**63**



**Grinding discs**  
ø 120mm  
Meules ø 120mm  
Ref #00063

**76**



**400g complete hopper**  
Bac à grains complet  
400g  
Ref #76100



**Ground coffee receptacle**  
Récupérateur de café  
Ref #76662



**Grinding discs ø 54mm**  
Meules ø 54mm  
Ref #00076

**59**



**1kg complete hopper**  
Bac à grains complet  
1KG  
Ref #59130



**Ground coffee receptacle**  
Récupérateur de café  
Ref #59662

**67**



**1kg complete hopper**  
Bac à grains complet  
1KG  
Ref #67102



**Ground coffee receptacle**  
Récupérateur de café  
Ref #67550

**01, 04, 40, 43, 55, 59 and 67 GRINDING DISCS MEULES**



**Poppy seeds discs**  
Meules pavot  
Ref #00011



**Pepper grinding discs**  
Meules poivre  
Ref #00002N



**Coffee grinding discs**  
Meules  
Ref #00001B

**40, 55, and 59 TOOLS OUTILS**



**Tool for grinder, for impact driver**  
Outil de démontage écrou, pour visseuse  
Ref #40981



**Tool for grinder, manual**  
Outil de démontage écrou, manuel  
Ref #40984

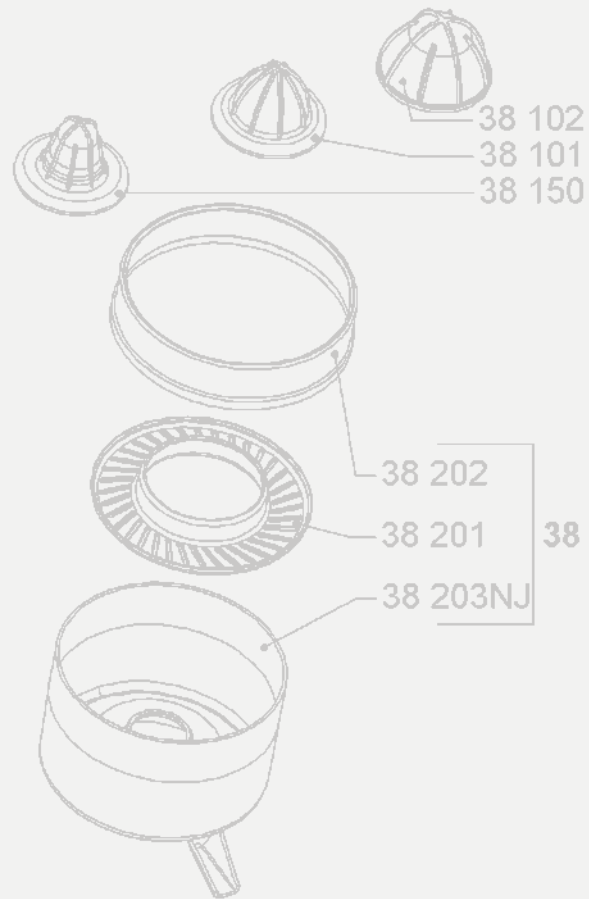

## DONNÉES TECHNIQUES

# *Technical data*

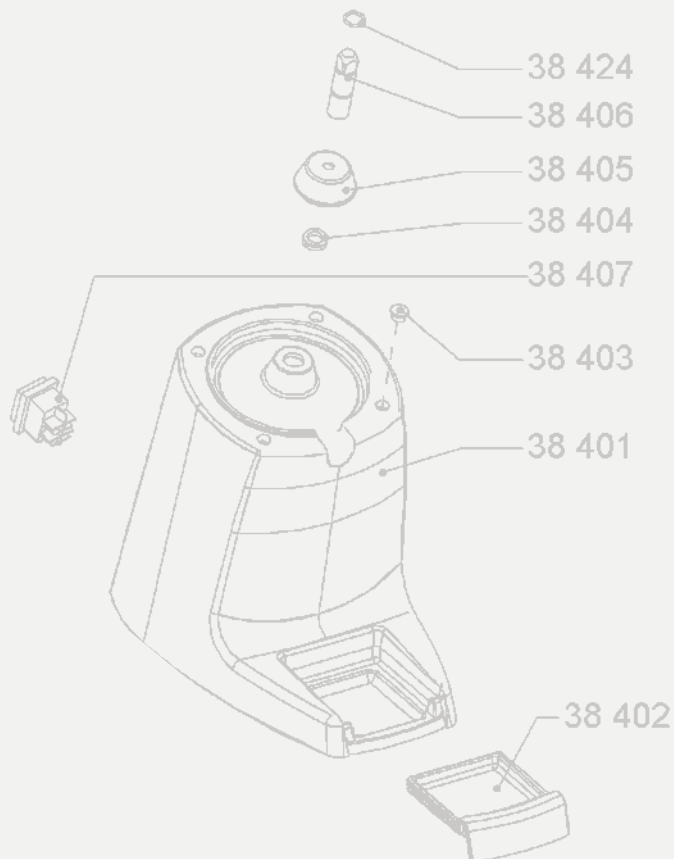

# Juice Bar Equipment

## Équipements pour bar à jus

	Référence Référence	Available voltages Voltage disponibles	Power Puissance (W)	Speed at 50Hz Vitesse à 50Hz (rpm; tr/min)	Specifications Spécifications	Standards Normes										Colors Couleurs			Dimensions (Dx WxH) mm (P x LxH) mm	Net weight (kg) Poids net (kg)
						CE	GS	UL / ETL	NSF	KC	EAC	Longtime	Stainless Steel   Inox	Chrome   Chromé	Black   Noir	Grey   Gris	Green   Vert			
<b>Citrus juicers   Presse agrumes</b>																				
71C	<b>Mefra citrus juicer - chromed base (1 squeezer)</b> Presse agrumes Mefra socle chromé (1 ogive)	71C	220-240V-50/60Hz	40	80	15 l/h	●											236x170x310	3,5	
		71CV1	100-120V-50/60Hz	40																
11	<b>“Classic” citrus juicer (3 squeezers)</b> Presse agrumes « Classic » (3 ogives)	11 / 11G / 11C	220-240-50/60Hz	130	1500	30 l/h	●		●									300x230x350	5	
		11V1 / 11GV1 / 11CV1	100-120V-50/60Hz	155																
38	<b>Citrus juicer (3 squeezers)</b> Presse agrumes (3 ogives)	38 / 38G / 38C	220-240-50/60Hz	130	1500	30 l/h	●		●									303x170x350	5	
		38V1 / 38GV1 / 38CV1	100-120V-50/60Hz	155																
52	<b>Citrus juicer (3 squeezers)</b> Presse agrumes (3 ogives)	52G / 52C	220-240-50/60Hz	230	1500	40 l/h	●		●									305x205x490	10	
		52GV1 / 52CV1	100-120V-50/60Hz	260																
10	<b>Automatic citrus juicer with lever</b> Presse agrumes à levier	10 / 10C	220-240V-50/60Hz	230	1500	30 l/h	●		●									300x200x380	9,5	
		10V1 / 10CV1	100-120V-50/60Hz	260																
70	<b>Lever Juicer Evolution 70 (1 squeezer)</b> Presse agrumes à levier 70 Evolution (1 ogive)	70 / 70C	220-240V-50/60Hz	300	1500	50 l/h	●		●									400x240x490	13,5	
		70V1 / 70CV1	100-120V-50/60Hz	420																
<b>Juice extractors   Extracteur de jus par centrifugation</b>																				
68	<b>New generation centrifugal juice extractor “Miracle Edition”</b> Extracteur nouvelle génération « Miracle Edition »	68 / 68X	220-240V-50/60Hz	1300	3000	140 l/h	●		●	●								490x330x603	25	
		68V1/68XV1	100-120V-50/60Hz	1300																
50	<b>Centrifugal juice extractor</b> Extracteur de jus par centrifugation	50 / 50C / 50X	220-240V-50/60Hz	800	3000	100 l/h	●		●	●								470x260x450	14	
		50V1 / 50CV1/50XV1	100-120V-50/60Hz	800																
28	<b>Centrifugal juice extractor</b> Extracteur de jus par centrifugation	28	220-240V-50/60Hz	1300	3000	100 l/h	●		●	●								465x320x510	24	
		28V1	100-120V-50/60Hz	1300																
<b>Cold Press Juicer   Extracteur de jus à pression lente</b>																				
65	<b>Cold press juicer</b> Extracteur de jus à pression lente	65	220-240V-50/60 Hz	400	5-70	60l/h	●		●									412x236x642	28,5	
		65V1	100-120V-50/60 Hz																	

### Standards | Normes :

- Approved | Approuvé
- \* Approved only for USA | Approuvé pour les Etats-Unis
- ▲ Pending | En cours

# Bar Equipment

## Équipements de bar

	Reference Référence	Available voltages Voltages disponibles	Power Puissance (W)	Speed at 50Hz Vitesse à 50Hz (rpm; tr/min)	Specifications Spécifications	Standards Normes										Colors Couleurs				Dimensions (DxWxH) mm (P x L x H) mm	Net weight (kg) Poids net (kg)
						CE	UL / ETL	NSF	KC	EAC	Longtime	Stainless Steel   Inox	Chrome   Chromé	Black   Noir	Grey   Gris	Green   Vert	Beige   Beige				
<b>Blenders, Drink mixers   Mixeurs, Shakers électriques</b>																					
62	Expert Brushless blender Blender Brushless Expert	62	220-240V-50/60Hz	1010	15000	1,4 l	●	▲	●	●	●	●	●	●	●	●	●	247x200x440	8,3		
		62V1	100-120V-50/60Hz	1010																	
66	Compact Brushless blender Blender Brushless Compact	66	220-240V-50/60Hz	1005	13000	1,4 l	●		●	●							233x197x393	6,2			
54	Drink mixer, electric shaker Shaker électrique, drink mixer	54N/54NEM	220-240V-50/60Hz	230	8000 - 16000	0,560 l	●	●	●									186x182x530	6		
		54V1	100-120V-50/60Hz	230																	
33E	Bar blender Evolution – bowl detection Mixeur de bar Evolution – détection de bol	33E / 33GE / 33CE	220-240V-50/60Hz	600	12000 - 16000	1,25 l	●	▲	●	●	●	●	●	●	●	●	●	180x180x420	3		
		33EV1/33GEV1/33CEV1	100-120V-50/60Hz	600																	
<b>Ice crushers   Broyeurs à glaçons</b>																					
09	Ice shaver Broyeur à glaçons	09	220-240V-50Hz	600	1500	1,6 kg/min	●											420x250x350	14,5		
		09V4	220-240V-60Hz	600																	
		09V1	100-120V-50/60Hz	650																	
53	Ice crusher Broyeur à glaçons	53	220-240V-50/60Hz	130	75	2,4 kg/min	●			●								353x236x474	10		
		53V1	100-120V-50/60Hz																		
<b>Cold drink dispensers   Distributeurs de boissons</b>																					
34-1	Cold drink dispenser (1 bowl x 12l) Distributeur de boissons réfrigérées (1 bac x 12 l)	34-1	220-240V-50/60Hz	130	-	12 l	●											430x190x545	15,5		
		34-1V1	100-120V-50/60Hz																		
34-2	Cold drink dispenser (2 bowls x 12l) Distributeur de boissons réfrigérées (2 bacs x 12 l)	34-2	220-240V-50/60Hz	335	-	2 x 12 l	●											430x380x545	23,5		
		34-2V1	100-120V-50/60Hz																		
34-3	Cold drink dispenser (3 bowls x 12l) Distributeur de boissons réfrigérées (3 bacs x 12 l)	34-3	220-240V-50/60Hz	470	-	3 x 12 l	●											430x570x545	30,5		
		34-3V1	100-120V-50/60Hz																		

### Standards | Normes :

- Approved | Approuvé
- \* Approved only for USA | Approuvé pour les Etats-Unis
- ▲ Pending | En cours



# Kitchen Equipment

## Équipements de cuisine

	Reference Référence	Available voltages Voltage disponibles	Power Puissance (W)	Speed at 50Hz Vitesse à 50Hz (rpm; tr/min)	Specifications Spécifications	Standards Normes				Colors Couleurs			Dimensions (DxWxH) mm (P x L x H) mm	Net weight (kg) Poids net (kg)
						CE	UL	EAC	Longtime	Stainless Steel   Inox	Grey   Gris	Beige   Beige		
<b>Kitchen blender   Blender de cuisine</b>														
37	<b>Santosafe® kitchen blender painted base only (without any bowl)</b> Blender de cuisine Santosafe® socle peint (Base seule sans bol)	37	220-240V 50/60Hz	1550	0-18000	-	●	●	●	●			310x210x560	9
374P	<b>Santosafe® kitchen blender painted base — 4 litre (1 gallon) transparent container</b> Blender de cuisine Santosafe® socle peint — Bol 4 litres Polymère (sans bisphénol A)	374P	220-240V 50/60Hz	1550	0-18000	4L	●	●	●	●			310x210x560	11
374I	<b>Santosafe® kitchen blender painted base — 4 litre (1 gallon) stainless steel container</b> Blender de cuisine Santosafe® socle peint — Bol 4 litres Inox	374I	220-240V 50/60Hz	1550	0-18000	4L	●	●	●	●			310x210x560	11
372P	<b>Santosafe® kitchen blender painted base — 2 litre (1/2 gallon) transparent container</b> Blender de cuisine Santosafe® socle peint — Bol 2 litres Polymère (sans bisphénol A)	372P	220-240V 50/60Hz	1550	0-18000	2L	●	●	●	●			310x210x560	11
372I	<b>Santosafe® kitchen blender painted base — 2 litre (1/2 gallon) stainless steel container</b> Blender de cuisine Santosafe® socle peint — Bol 2 litres Inox	372I	220-240V 50/60Hz	1550	0-18000	2L	●	●	●	●			310x210x560	11
<b>10 litre dough mixer   Pétrin 10 litres</b>														
18	<b>10 litre dough mixer (kneader) stainless steel bowl</b> Pétrin mélangeur 10 litres — cuve inox	18	220-240V-50Hz	600	70	4 kg	●	●	●	●	●	●	500x350x420	18,5
		18V1	100-120V-50/60Hz	650										
<b>Grater   Râpe</b>														
02	<b>Grater (1 standard disc)</b> Râpe (1 disque standard)	02	220-240V-50Hz	600	1500	50 kg/h	●	●	●	●	●	●	420x250x350	14,5
		02V4	220-240V-60Hz	600										
		02V1	100-120V-50/60Hz	650										
<b>Meat mincer   Hachoir à viande</b>														
12-12	<b>Meat mincer — stainless steel mincer body</b> Hachoir à viande — corps inox	12-12 / 12-12R	220-240V-50/60Hz	600	140	160 kg/h	●	●	●	●	●	●	350x260x420	19
		12-12V1 / 12-12RV1	100-120V-50/60Hz	650										

### Standards | Normes :

- **Approved** | Approuvé
- \* **Approved only for USA** | Approuvé pour les Etats-Unis
- ▲ **Pending** | En cours

# Coffee Shop Equipment

## Équipement pour Coffee shops

	Reference Référence	Available voltages Voltage disponibles	Power Puissance (W)	Speed at 50Hz Vitesse à 50Hz (rpm; tr/min)	Specifications	Standards Normes				Colors Couleurs			Dimensions (D x W x H) mm (P x L x H) mm	Net weight (kg) Poids net (kg)	
						CE	UL / CTUV US	KC	EAC	Longtime	Stainless Steel   Inox	Brown   Brun			Black   Noir
<b>Specialty Coffee   Moulins à café de spécialité</b>															
01 BAR	<b>Coffee grinder championship edition</b> Moulin à café édition barista	01 BAR	220-240V-50/60Hz 100-120V-50/60Hz	600	1500	14 kg/h	●				●		330x190x560	14.5	
67	<b>I-Grind Coffee Grinder</b> Moulin à café I-Grind	67	100-240V-50/60Hz	1010	2800	25 kg/h	●	▲				●	362x226x520	11.5	
76	<b>Kawa Coffee Grinder</b> Moulin à café Kawa	76	220-240V-50/60Hz	1150	3000	18 kg/h	●	▲				●	270x180x400	7.5	
		76v1	110-120V -50/60Hz	800											
<b>Espresso coffee grinders   Moulins à café bar (espresso)</b>															
40AN	<b>Autom. silent espresso coffee grinder</b> Moulin à café bar doseur auto. silencieux	40AN	220-240V-50Hz	360	1500	8 kg/h	●		●	●		●	●	390x190x580	14
		40ANV4	220-240V-60Hz	360											
		40ANV1	100-120V-50/60Hz	310											
55BF	<b>Automatic espresso coffee grinder</b> Moulin à café espresso automatique	55BF	220-240V-50/60Hz	1150	2850	25 kg/h	●		●			●	397x198x540	15	
		55BFV1	100-120V-50/60Hz	800											
55BAR	<b>Automatic espresso coffee grinder</b> Moulin à café espresso automatique	55BAR	220-240V-50/60Hz	1150	2850	25 kg/h	●		●			●	397x198x540	15	
		55BARV1	100-120V-50/60Hz	800											
55 W	<b>Automatic espresso coffee grinder</b> Moulin à café espresso automatique	55W	220-240V-50/60Hz	1150	2850	25 kg/h	●		●			●	397x198x540	15	
		55WV1	100-120V-50/60Hz	800											
59	<b>On-demand coffee grinder</b> Moulin à café « on-demand »	59	220-240V-50/60Hz	1150	2850	25 kg/h	●	●				●	352x198x540	14.9	
		59V1	100-120V-50/60Hz	800											
59 W	<b>On-demand coffee grinder</b> Moulin à café « on-demand »	59W	220-240V-50/60Hz	1150	2850	25 kg/h	●		●			●	352x198x540	14.9	
		59WV1	100-120V-50/60Hz	800											
59 T	<b>On-demand coffee grinder</b> Moulin à café « on-demand »	59T	220-240V-50/60Hz	1150	2850	25 kg/h	●	●				●	352x198x540	14.9	
		59TV1	100-120V-50/60Hz	800											
59 TW	<b>On-demand coffee grinder</b> Moulin à café « on-demand »	59TW	220-240V-50/60Hz	1150	2850	25 kg/h	●	●				●	352x198x540	14.9	
		59TWV1	100-120V-50/60Hz	800											
<b>Precision coffee dispenser   Doseur Espresso de précision</b>															
26	<b>Tabletop precision coffee dispenser</b> Doseur espresso de précision sur socle	-	-	-	-	-	●						293x200x352	4,3	
<b>Coffee shop grinders   Moulins à café boutiques et coffee shops</b>															
01	<b>Coffee grinder with drawer or bag holder</b> Moulin à café — tiroir ou pince-sac	01	220-240V-50Hz	600	1500	14 kg/h	●					●	320x250x550	14	
		01V4	220-240V-60Hz	600											
		01V1	100-120V-50/60Hz	650											
01P	<b>Pepper (spices) grinder with drawer</b> Moulin à poivre (épices) — tiroir	01P	220-240V-50Hz	600	1500	14 kg/h	●					●	320x250x550	14	
		01PV4	220-240V-60Hz	600											
		01PV1	100-120V-50/60Hz	650											
04N	<b>Coffee grinder with bag holder</b> Moulin à café — pince-sac	04	220-240V-50Hz	600	1500	14 kg/h	●					●	320x220x700	18	
		04NV4	220-240V-60Hz	600											
		04NV1	100-120V-50/60Hz	650											
43N	<b>Silent shop coffee grinder with bag holder</b> Moulin à café boutique silencieux — pince-sac	43N	220-240V-50Hz	600	1500	14 kg/h	●		●			●	350x190x685	20	
		43NV4	220-240V-60Hz	600											
		43NV1	100-120V-50/60Hz	650											
63	<b>Coffee Shop Grinder</b> Moulin à café Coffee Shop	63	220-240V-50Hz	1500	1500	120 kg/h	●					●	329x265x677	40	
		63V4	220-240V-60Hz												
		63V1	100-120V-50/60Hz												

Standards | Normes :  
 ● Approved | Approuvé  
 ▲ Pending | En cours





**Food and Beverage**  
Equipment Provider



140-150, avenue Roger  
Salengro — BP 80 067  
69511 Vaulx-en-Velin  
Cedex (Lyon) France

Tél. : +33 4 72 37 35 29  
E-mail : [santos@santos.fr](mailto:santos@santos.fr)  
[www.santos.fr](http://www.santos.fr)

Follow us on **#santosaddict**  
social networks

